

Rejector

Flipper Type

- Pneumatic
 - Three-Way
 - Checkweigher
 - Waterproof
 - Self-Standing
- X-ray Inspection System, Metal Detector

*The speed varies depending on a product to be rejected.

Flipper Type

KRA4102AW

Made to Order

Maximum product size	Width	120 mm
	Length	150 mm
	Height	60 mm
	Weight	0.6 kg

KRA4103AW

Maximum product size	Width	220 mm
	Length	300 mm
	Height	200 mm
	Weight	2 [3] kg

KRA4104AW

Maximum product size	Width	350 mm
	Length	600 mm
	Height	500 mm
	Weight	10 [5] kg



External Dimensions

KRA4102AW

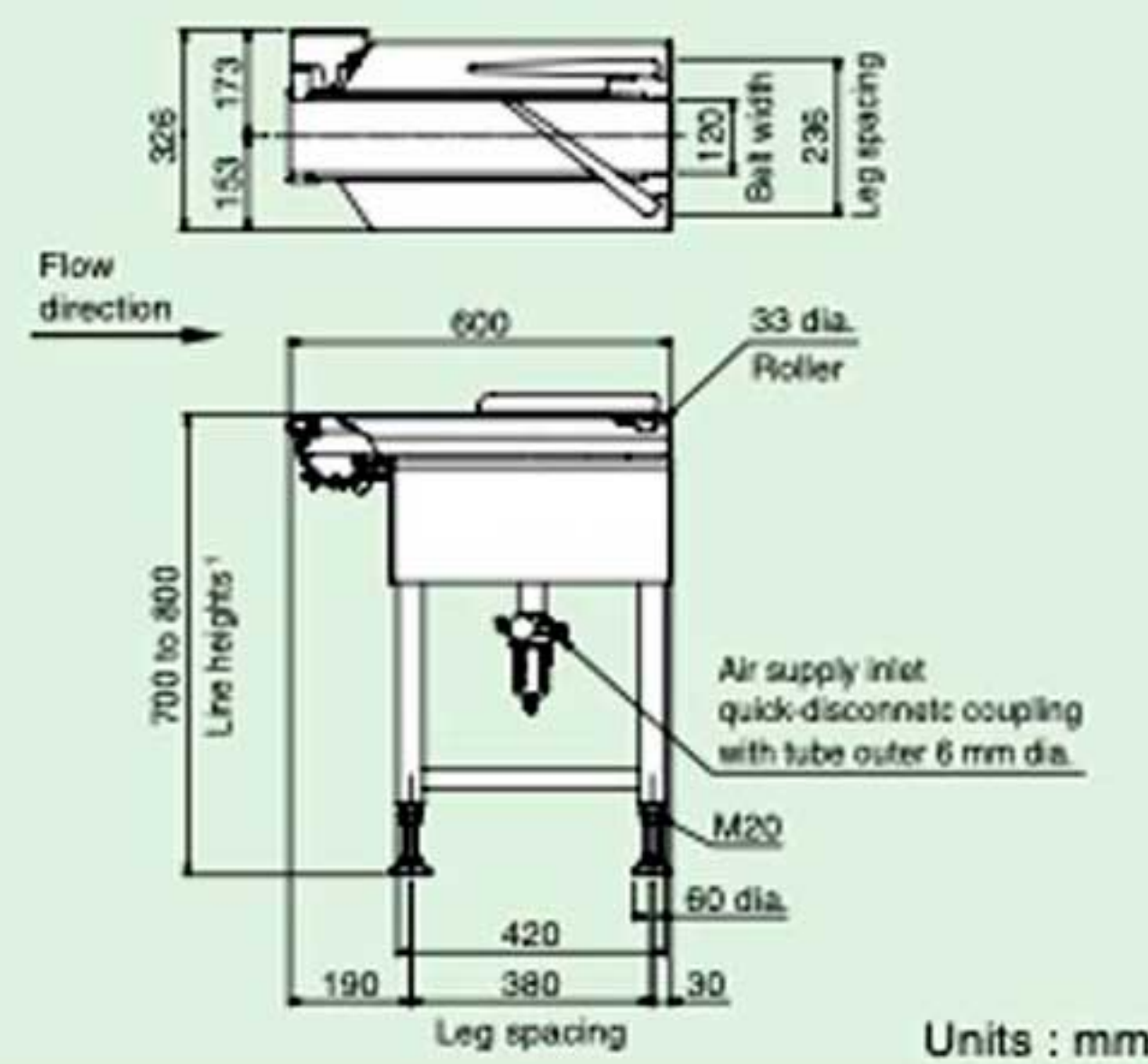

KRA4103AW

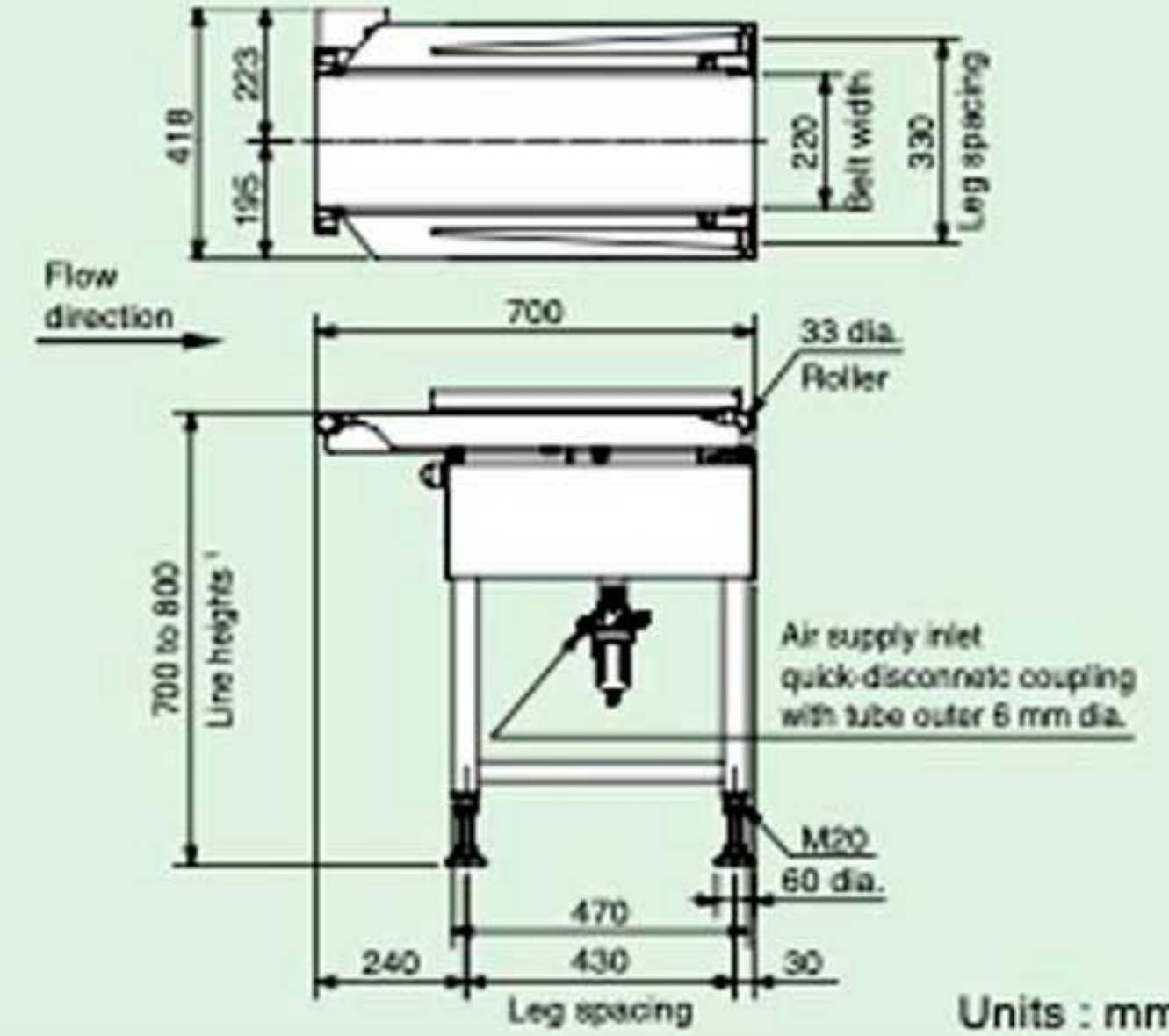

KRA4104AW

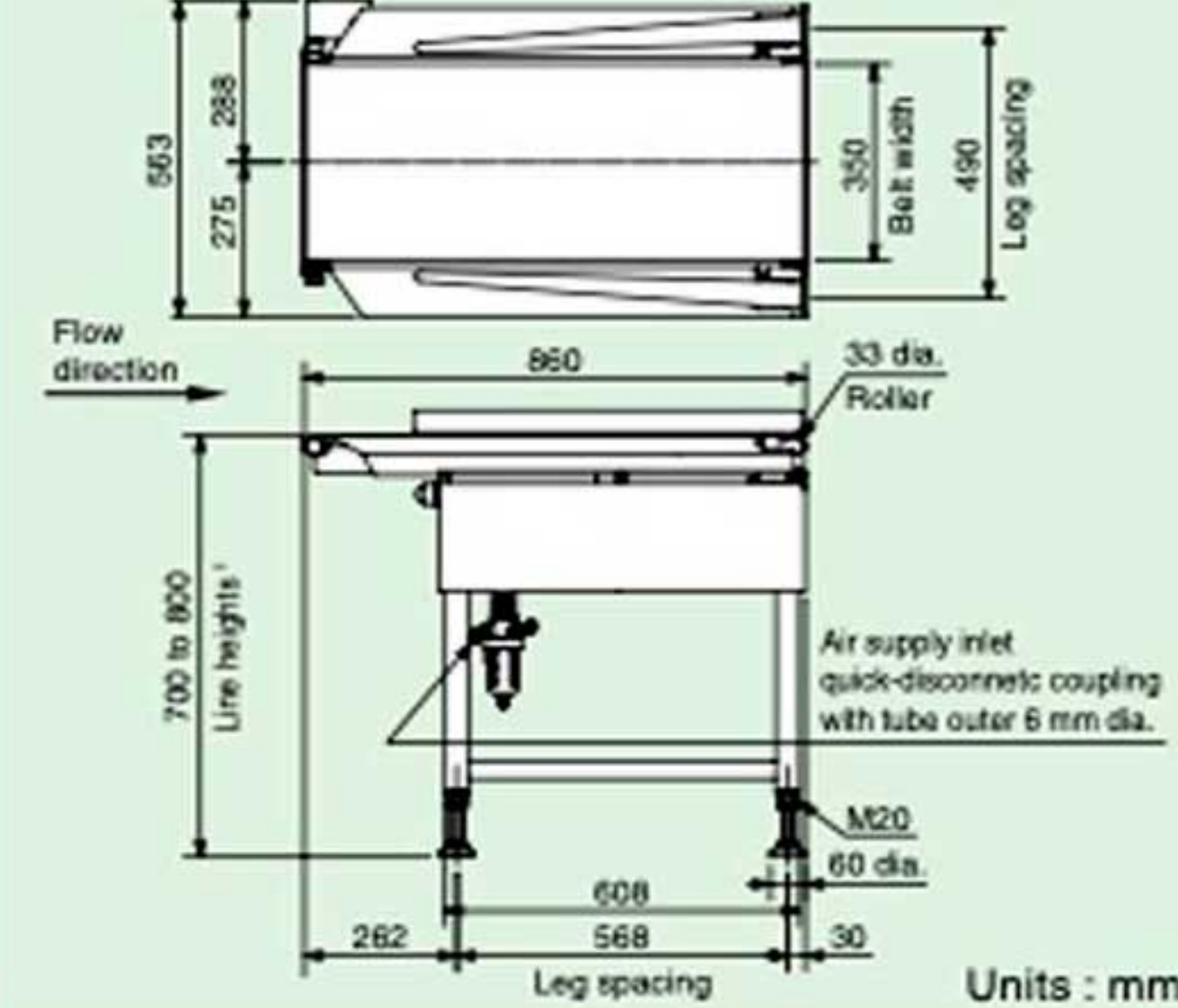

1: 550±50 mm to 1000±50 mm are available as an option.

Specifications



Model	KRA4102AW Made to Order	KRA4103AW	KRA4104AW
Gate drive system	Pneumatic drive		
Classification	3		
Maximum product size and weight	Width (mm)	220	350
	Length (mm)	300	600
	Height (mm)	200	500
	Weight (kg)	2 [3] ^{Note 1}	10 [5] ^{Note 1}
Maximum speed (products/min)	200	150 [120] ^{Note 1}	45 [70] ^{Note 1}
Belt speed (m/min)	10 to 115	10 to 102 [5 to 77] ^{Note 1}	5 to 49 [5 to 77] ^{Note 1}
Air requirements	0.4 to 0.9 MPa, 4 l/min [A.N.R.]		
Air inlet	Tube having outer diameter of 6 mm		
Power requirements	100 Vac to 120 Vac +10% -15% or 200 Vac to 240 Vac +10% -15%, single phase, 50/60 Hz (Supplied from SV/SSV series, IP series Checkweigher)		
Power consumption	Stationary 70 VA, maximum 150 VA (inrush current 10 A)		
Mass	43 kg	45 kg	70 kg
Environmental conditions	0°C to 40°C, relative humidity 30% to 85%, non-condensing		
Protection class	IP66 compliance		
Exterior	Stainless steel (SUS304) (excluding some parts)		
Connectable model	Checkweigher, X-ray inspection system, Metal detector		

Note 1 : Figures in [] are optional.